



# REFRIGERATION

SERVING THE FOOD INDUSTRY SINCE 1951

## 24-INCH OPEN REFRIGERATED FLOOR DISPLAY CASE

Item: 25825 Model: RS-CN-0250



**KEEP YOUR PRODUCTS PROPERLY CHILLED AND INCREASE IMPULSE**

Ideal for restaurants, cafes, and/or bakeries, Omcan's 24-inch open refrigerated floor display case is perfect for your customers to easily see what products are for sale. Featuring its crystal clear glass design, this display case has interior LED lighting, which brings highlight to your foods, as well as digital temperature controls. It also features pull down curtain and adjustable shelf positions.

Product may not be exactly as shown.

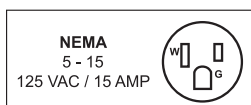

SPEC SHEET UPDATED: April 17, 2023



Authorized Dealer

# REFRIGERATION

24-INCH OPEN REFRIGERATED FLOOR DISPLAY CASE 25825



## FEATURES

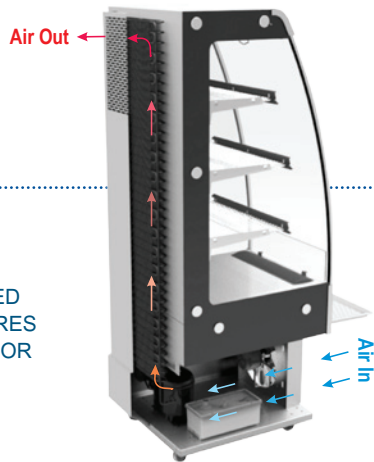

CONDENSER LOCATED ON THE BACK, ENSURES SUFFICIENT SPACE FOR AIR COOLING



CONDENSER FAN MOTOR BUILT IN FRONT FOR EASY ACCESS



EQUIPPED WITH DIGITAL DISPLAY, HIDDEN CASTERS & TWO ADJUSTABLE FEET



REMOVABLE FILTER NET MAKES CLEANING EASY

## TECHNICAL SPECIFICATION

ITEM NUMBER	25825
MODEL	RS-CN-0250
POWER	0.138 kW
ELECTRICAL HEATING ELEMENT	0.45 kW
CAPACITY (L / CU. FT.)	252 L / 8.9 cu. ft.
ELECTRICAL	110V/60Hz/1Ph
LAMP POWER (W)	1.44*4 (LED)
TEMPERATURE RANGE	2 - 10°C / 36 - 50 °F
REFRIGERANT & INJECTION	R290 (148g)
BLOWING GAS	Cyclopentane
TYPE OF CLIMATE	6
RATED CURRENT (A)	14.5A
WEIGHT	220.5 lbs. / 100 kg.
PACKAGING WEIGHT	242.5 lbs. / 110 kg.
OVER-ALL DIMENSIONS	24" x 29.7" x 67" / 610 x 754 x 1704 mm
INNER DIMENSIONS	21.7" x 22" x 38.5" / 552 x 559 x 978 mm
SHELF SIZE	15" x 21.7" / 381 x 552 mm (2pc.) 12" x 21.7" / 305 x 552 mm (1pc.)
PACKAGING DIMENSIONS	27.2" x 32.6" x 73.8" / 691 x 830 x 1875 mm

## TECHNICAL DRAWING AND DIMENSIONS

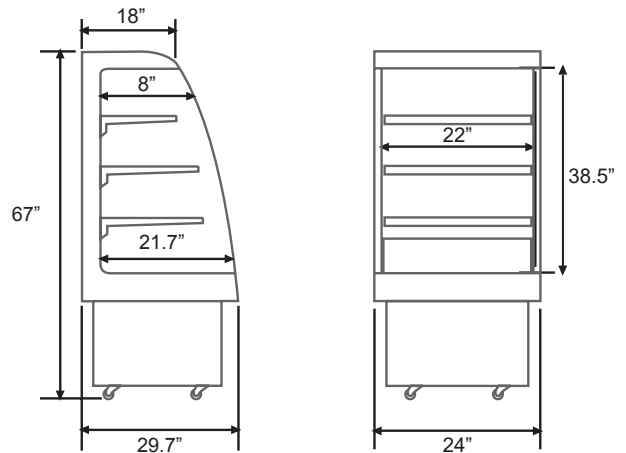

**WARRANTY**  
PARTS AND LABOR

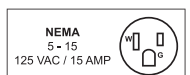

**OMCAN INC.**

Telephone: 1-800-465-0234

Fax: (905) 607-0234

Email: sales@omcan.com

Website: www.omcan.com



Follow us to keep up to date with the latest news and offers



E.O.E